

- Power Supply** : 220V. 50Hz. standby ~11W. Max. ~65W.
- Wing** : Single-sided Ø40mmx2,5mm anodised hard mat aluminium profile wing frame welded at the connection points equipped with plexiglas flap. (Opt. 304-grade stainless steel wing frame profile)
- Dimensions** : 500x955x300 + wing length (450 - 900mm)
- Weight** : ~40 kgs
- Body Features** : 1,5 mm 304-grade stainless steel protected against water for external utilisation.
- Working Temperature** : -15°C/+65°C (Ops. -50°C with heater unit)
- Working System** : It is a motorised system that operates bi-directionally. After the passage signal is being received, the system unlocks the wing and wing waits for being pushed softly. After the soft push, the wing turns by 90° and keeps that position. Through the predetermined time interval or via the remote control, the wings get back to its original position and the system locks itself. If the wing is forced by an obstacle during the opening operation, it stops moving and after a short move backward it restarts to move forward. This movement is repeated twice under the case of facing with an obstacle on the way, and if it is still being forced, the system alerts. In case of emergency, the wings free themselves to allow free passageway.
- Control System** : Can be controlled through dry contact or any tension in between TTL. CMOS. 5-48v. Can be operated harmoniously with all kinds of access control units and token system when integrated. The functions can be controlled via RS 232, RS 485 or LAN network.
- Indicators** : Direction indicators are built-in property.

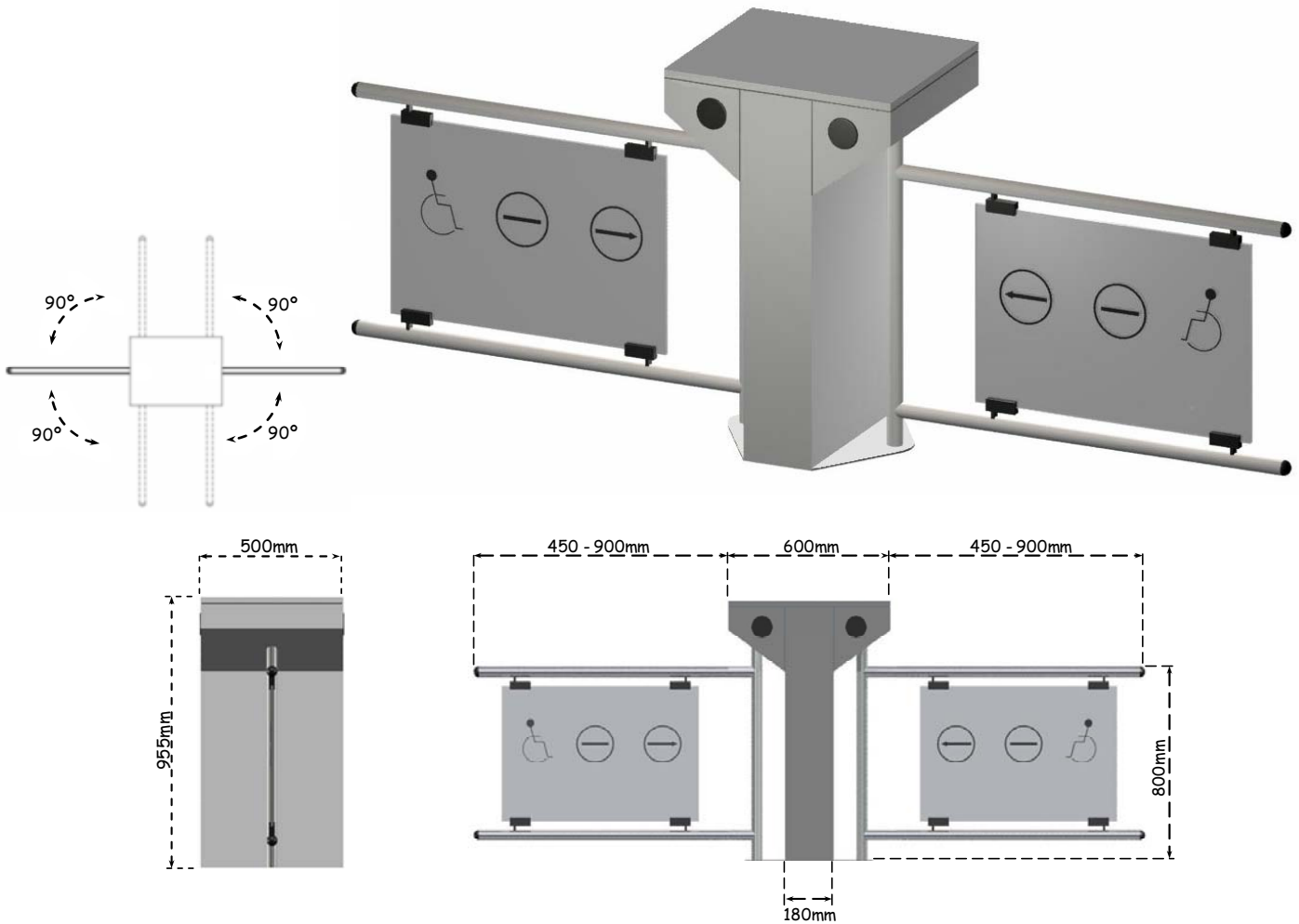

- Power Supply** : 220v. 50Hz. at standby ~22 W. Max. ~130W.
- Wing** : Double-sided Ø40mmx2,5mm anodised hard mat aluminium profile wing frame welded at the connection points equipped with plexiglass flap. (Opt. 304-grade stainless steel wing frame profile)
- Dimensions** : 500x955x600 + wing length (2x470mm)
- Weight** : ~62 kgs
- Body Features** : 1,5 mm 304-grade stainless protected against water for external utilisation.
- Working Temperature** : -15°C/+65°C (Ops. -50°C with heater unit)
- Working System** : It is a motorised system that operates bidirectionally. After the passage signal is being received, the system unlocks the wing and wing waits for being pushed softly. After the soft push, the wing turns by 90° and keeps that position. Through the predetermined time interval or via the remote control, the wings get back to its original position and the system locks itself. If the wing is forced by an obstacle during the opening operation, stops moving and after a short move backward it restarts to move forward. This movement is repeated twice under the case of facing with an obstacle on the way, and if it is still being forced, the system alerts. In case of emergency, the wings free themselves to allow free passageway.
- Control System** : Can be controlled through dry contact or any tension in between TTL. CMOS. 5-48v. Can be operated harmoniously with all kinds of access control units and token system when integrated. The functions can be controlled via RS 232, RS 485 or LAN network.
- Indicators** : Direction indicators are built-in property.